

Note sulla revisione

REV	Descrizione
01	Unificata tavola punzoni standard e con taglio sfrido. Nella serie standard rivisti i superiori con doppio smusso su punta.

S :
Superiore
Upper

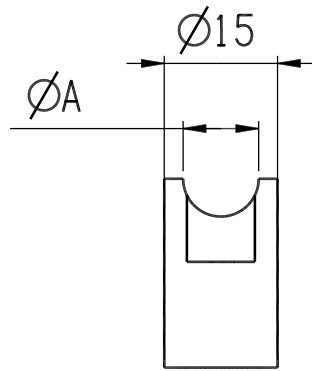
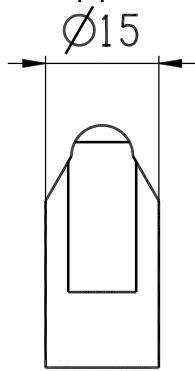

Isonemtric view

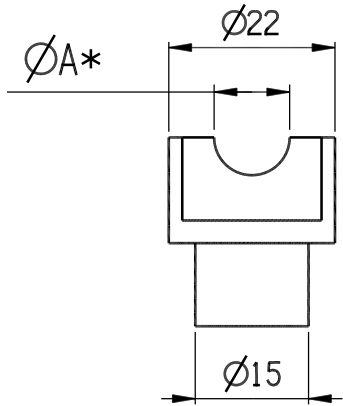
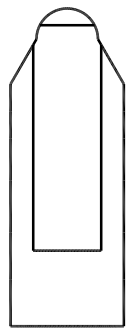
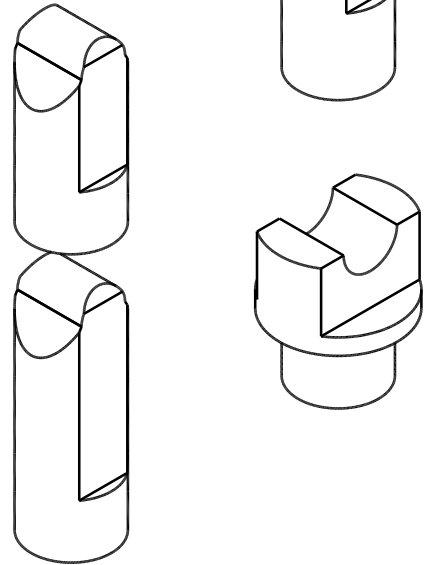

S :
Superiore TS
Upper TS

I :
Inferiore
Lower

Codice-Code	S/I	Ø A
EL-DF001-AA-00	S	Ø 4
EL-DF003-AA-00	S	Ø 6
EL-DF005-AA-00	S	Ø 8
EL-DF007-AA-00	S	Ø 10
EL-DF009-AA-00	S	Ø 12
EL-DF011-AA-00	S	Ø 14
EL-DF013-AA-00	S	Ø 15
DF002	I	Ø 4
DF004	I	Ø 6
DF006	I	Ø 8
DF008	I	Ø 10
DF010-AB-00*	I	Ø 12
DF014	I	Ø 15

*Modello con gambo maggiorato
Model with bigger arbor

SERIE "TS": Taglio sfrido "TS": with cutting, series		
Codice-Code	S/I	Ø A
DFTS003-AA	S	Ø 6
DFTS005-AA	S	Ø 8
DFTS007-AA	S	Ø 10
DFTS009-00	S	Ø 12
DFTS011-AA	S	Ø 15
DFTS004-AA	I	Ø 6
DFTS006-AA	I	Ø 8
DFTS008-AA	I	Ø 10
DFTS010-AA*	I	Ø 12
DFTS012-AA	I	Ø 15

*Modello con gambo maggiorato
Model with bigger arbor

CASTECH SRL	SCALA 1 : 1	FORMATO A4	DISEGNATO: Diego Fin	DATA 14/07/15	N° PEZZI PER MACCHINA 1	MACCHINA DI APPARTENEZA	SEMILAVORATO DI APPARTENEZA
			VERIFICATO: Diego Fin			CODICE:	CODICE:
MATERIALE Molibdenum 99,9%						TRATTAMENTI	
DESCRIZIONE TAVOLA ELETTRODI SERIE DF/ TABLE ELECTRODES DF MODEL					N° DISEGNO TV-ELDF-AA	REVISIONE 01	